



# HEAD OF THE CLASS

You only invest high four-figure amounts into your hobby if you expect something extraordinary in return – so do these top-class headphones by HiFiMan, Sennheiser, and Stax meet those high expectations?



Lounging comfortably in an armchair at 30C, playing around with some top-quality headphones, we can't shake this certain feeling of „déjà-vu“: after all, didn't we do the same thing last year, during a heatwave? Yes, we did, and then we noticed very quickly and very clearly whether and how fast the ears start to burn under the ear-cushions and start sweating. One thing is certain: once your ears get too hot, the topic of headphones and their sound flies out of the window and you look for something else to do – but time, tide and temperature wait for no man when there are headphones to be auditioned.

*Michael Lang*

**We tested the following:**

HiFiMan Edition X	XX
Sennheiser HD 800 S	XX
Stax SR-L 700	XX

# NO HALF MEASURES

The price for the Edition X was cut almost by half from the HE-1000i – how much sound did they lose on the way?

The only thing we had to complain about when we tested the €3500 HiFiMAN HE-1000i one year ago was its exorbitant price: considering the headphones were produced in China, we were unable to understand the brand's 'ambitious' pricing. However, the HE1000i's little brother, the Edition X, has been available for a while now at about € 2,000, so we wanted to know where money has been saved in order to get the price down by € 1,500.

One good thing is that the red ink didn't feature at the heart of the headphones, the magnetostatic drivers: those in the Edition X are based on the technology of the 1000 series, but have better efficiency. The idea behind this is simple: even with the lower impedance of only 25 Ohms, users of inexpensive portable devices should still be able to enjoy the sound of top headphones. And while this works technically, as a test with a

MacBook showed, overall it only makes limited sense since the quality available here is only apparent when you connect the Edition X to a DAC/headphone amp like an Audioquest Dragonfly. At this point the headphones become alive and dynamic, Johnny Cash's voice regaining its body and the vibrations of his guitar adding to the sonic experience. And when connected to the and even better headphone amp, from Lehmann, the timbre moves safely to a tiny hint of brightness.

If the "HiFiMEN" cut corners, then they probably only did so in the design of the headband construction – and the weight. The package they put together fits together very well.



▲ Headband and earpiece materials are simpler than in the flagship HE-1000i.



▲ The cables can be exchanged, with a balanced version available for a surcharge.

**HIFIMAN EDITION X**

Price: about € 2,000, Weight: 400 g  
 Warranty: 2 years  
 Contact: Sieveking Sound  
 Tel.: +49 421/6848930  
 www.sieveking-sound.de

---

At 400 g, the weight of the HiFiMAN is still just in the comfort zone. Good efficiency and low impedance make it a sonic master!

**FEATURES**

Metal headband with leather, left/right labels, replaceable ear cushions; 3 m cable with 6.3 mm jack and 1.5 m with 3.5 mm jack included

**STEREO-TEST**

<b>SOUND QUALITY</b>	<b>93%</b>
<b>PRICE/PERFORMANCE</b>	
<span style="color: #c00;">★</span> <span style="color: #c00;">★</span> <span style="color: #c00;">★</span> <span style="color: #c00;">☆</span> <span style="color: #c00;">☆</span>	
<b>VERY GOOD</b>	

# UNMASKED

With its patented absorber technology, the German manufacturing legend Sennheiser wants to make its top-selling HD 800 future-proof.

The HD 800 has been our office workhorse for years: whenever we want to set a sonic benchmark, we turn to the Sennheiser. If we need to decipher the mumbled words of an interview subject, possibly even in English, we know which headphones to reach for: impossible to fool, and with the neutrality of a referee, the HD 800 helps our editors clearly distinguish good from better.

The Sennheiser secret? The company, which is based in lower Saxony, saw the potential in getting higher frequencies to the ear without interference, while at the same time still providing lower frequencies at great volumes. Preventing resonances arising in the space between driver and ear minimized this effect, known in the jargon as “masking”, the necessary mechanical modifications being not dissimilar from the principle of a Helmholtz resonator. However, it’s not a matter of soaking up those excess bass energies which do the masking, but rather smoothing out the frequency response in the upper range, which is supposed to lead to a more pleasant, rounder sound.

## Not just painted black

Whether you prefer the black exterior to the traditional silver look is a matter of taste. But it is nice that this “S-Class” version comes with an alternative 4-pole balanced cable: with a corresponding amp, in our case a Malvalve, this results in audibly more dynamic range and openness.

Occasionally the ‘standard’ 800 is accused by some of being a little devoid of emotion – and not without reason if you take Ryan Adams’ “Invisible Riverside” as an exemplar. You can detect a slight wisp of coolness, with a gentle peak in the high range. The “S” has a bit more heart and soul, without sacrificing its qualities as a working device, due to the absence of those resonances.

It’s the holy grail of development: keeping all the good qualities and making something else even better: like a VW Golf which offers more interior space with the same body length, uses less gas, and corners with even more agility – that’s the scale of the task the development team had to tackle. But Sennheiser appears to have an eye - or ear - for this, just like their automotive counterparts in Wolfsburg.

The differences became even clearer in balanced operation. Complex orchestral music like Respighi’s “Pines of the Appian” on our STEREO Sound Test CD VI gained more detail and consistency than with the normal 800 – not worlds apart, but readily apparent, and the same was true with complex rock music like Wilco’s “Born Alone”, as if the door was simply opened wider. Even Jan Josef Liefers’s abilities as audio-book reader reached the listener airy, light, and with many facets: subtly better, if not dramatic differences. Owners of the 800 need not jump ship just yet, but the HD 800 S is easy to recommend if you’re in the market for a new pair of headphones. The fine-tuning, albeit with a moderate price increase, is definitely a success.



### SENNHEISER HD 800 S

Price: about € 1,600, Weight: 330 g  
 Warranty: 2 years  
 Contact: Sennheiser  
 Tel.: +49 5130/6000  
 www.sennheiser.de

The Sennheiser weighs just about 330 g – and thus passes as light-weight. Good efficiency but relatively high impedance make it an ideal playmate for a high-quality amp. In terms of sound just a fraction better than the standard model!

#### FEATURES

High-quality housing, cushioned headband with leather cushion, left/right labels, replaceable ear cushion; 3 m cable with 4-pole XLR plug, cable with 6.3 mm jack included

#### STEREO-TEST

SOUND QUALITY **91%**

PRICE/PERFORMANCE



**VERY GOOD**

# STAX OF INNOVATIONS

Stax news – it's been a contradiction in terms in the past few years. Well, the wait is over.



The last time I put on a new Stax headphone was when we received the current top model, the 009, for testing three years ago. Since then these Japanese electrostatic models, which pretty much used to rule the high-class headphone roost, have gained some competition: the global boom in 'personal listening' has given a few companies the courage to enter into market sectors once seen as 'Stax territory'.

## Needing good companions

Since the Stax SR-L700, like the company's other 'earspeakers', is an electrostatic type, it requires its own amp to generate the high voltage needed to drive the diaphragms. True, a few manufacturers have brought out electrostats without the need for this high voltage, but the Japanese have chosen to stick with this 1960 technology, to the extent of building amps to fit round their headphone range. In our case that meant the most affordable amp, the SRM 006tS, available in Germany packaged with the 700 'phones as the SRS 7106 Pro for € 3,375 – quite a saving over buying the two individually.

'More expensive than dynamic headphones plus a decent amp' you say? Not really – if you want to get the maximum out of the two other test candidates here you'd need to choose their balanced cable version and buy a correspondingly-equipped headphone amp. Do that, and it's pretty likely that the complete price such a set would lie above that of the Stax package.

However, if you are looking for a better price, you should look at the SR-L 500 Pro and SR-L 300 models, which come in at € 900 and € 525 respectively.

If a system has achieved a certain maturity, which we can safely assume Stax has after more than five decades, then progress usually arises more from changing details than from a complete redesign. Still, when you look at the 700 headphone, then quite a bit had to change to bring its performance closer to that of the flagship SR-009: so while the headphones haven't become bulkier on the outside, they do offer more volume within, the electrostatic elements being rearranged and the inner damping mechanism changed.

The conductor plates including the electrodes have been stabilized as in the '009: they now have a greater thermal capacity and can therefore handle high volumes

with less distortion. In fact you cannot manage the volume reserves here, you should probably visit your ENT specialist and subject your own sound detectors to a check-up and possible flush.

However, Stax was still not satisfied with these innovations: its engineers also added an extremely low-capacitance silver-plated 6N pure copper cable. It's 2.5m long, and connected permanently to the headphones, flying in the face of the current interchangeable cable trend, but if you need more flexibility, you can order 2.5m or 5m extension cables.

Two permanent points of criticism have also been resolved. The ear cushions used to be less than ideal for really long sessions, for instance when listening to a complete audio play or an opera, but the new design is, the manufacturer says, both ergonomically shaped and lined with lamb's leather.

And the plastic headband, which had always felt cheap, has been replaced with a metal version having 10 adjustment settings, particularly for the very demanding German market. To prevent these from damaging the plastic housing of the drivers when handled roughly, they are merely clicked in and jump out of the mount when lateral pressure is applied. Why wasn't it like that from the beginning, we wonder?

### The SRM-006ts headphone amp: license to thrill

The recommended SRM-006ts headphone amp is worth a closer look, too, and tube lovers will prick up their ears when they hear the word "triodes": there are two 6FQ7 dual triodes in the output stage. The circuit design is balanced, the four-fold potentiometer with channel-separated volume control showing how consistent the designers were here: a balun isn't used, simply because Stax believes they limit frequency response.

The 006 has three inputs – one of which is balanced – switched with relays and with a red LED to indicate which input has been selected; the power button is also on the front, lighting up a green LED when running. However, we would have liked an LED on the volume control so that you can see how high it's set, even in low lighting.

It is important to know that the 006 provides the especially high bias required by the Pro series, and two headphones can be connected at the same time. But



◀ The headband is finally made out of metal, the housing still plastic, the cushions made from lamb's leather – very comfortable to wear.

One output, three inputs, one of which is symmetric, and a grounding clamp in case there is a buzz in the line. ▶



the amp should be given plenty of space, rather than simply being stuffed onto a shelf with just a few centimeters of air around it: it can get quite hot.

### Great, whatever the music

After a decent warm-up period any trace of dullness and an initial slightly nasal quality had completely disappeared, meaning that Jan Josef Liefers, who thrills audiences with crime stories in audio form, came across airily in "Dr. Siri and seine Toten", with finely nuanced volume differences from the wafer-thin membranes. The presentation was powerful and effortless, the various roles Liefers plays in this crime story set in China reproduced with ease and skill.

If I had initial doubts about its suitability for rock music, this Stax combo completely won me over: Mando Diao's unplugged "Before Rock 'n' Roll" sounded light and transparent, driving, and with a bass which came across completely clean. Similarly the Red Hot Chili Peppers' "Goodbye Hooray" sounded powerful, the bass figures of Michael Balzary as clear as the art of his colleague on the drums. The sound remained just as precise when things got wild.

Puccini's "Turandot" was projected onto a large canvas: a real XXL stage in which the light and pleasant 700 disappeared acoustically without neglecting to play out every single sound event in its precise location, with not a hint of diminution of scale and a simply magical

presentation of a Birgit Nilsson who was at the zenith of her art in 1959.

American singer Lyn Stanley certainly also belongs into the category of enchanting voices, and since she also has a keen eye for top recording quality, every piece on here "Interludes" set is a sonic jewel: listening to how Stax carves out every detail of her voice and her excellent accompaniment makes an investment into a headphone set of this caliber almost a must!

### STAX SR-L700 SRM 006 TS

Set price: about € 3,750, Weight: 370 g  
 Warranty: 2 years  
 Contact: Audio Trade  
 Tel.: +49 208/8826660  
 www.audiotra.de

At about 370 g neither sound nor weight stand in the way of long sessions. The processing is more sophisticated than in earlier Stax models. It can get loud, bass and impulsivity are excellent. The 006 is the perfect supplement as driver.

#### FEATURES

Plastic housing, metal headband with leather cushion, left/right labels, replaceable ear cushions; fixed 2.5 m cable with special plug

#### STEREO-TEST

SOUND QUALITY **99%**

PRICE/PERFORMANCE



**VERY GOOD**

## HOW THEY WORK: ELECTROSTATIC, DYNAMIC, AND MAGNETOSTATIC HEADPHONES

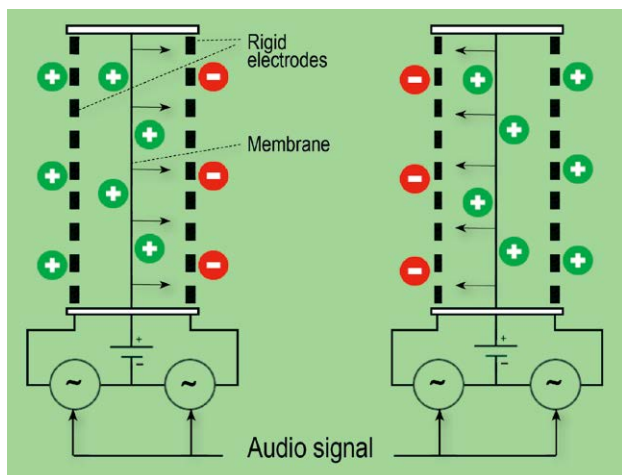

### HIGH VOLTAGE: ELECTROSTATS

Headphones by Stax & Co. cannot simply be operated „passively“ on a jack plug but need a special supply system. It generates DC voltage for the diaphragm – a wafer-thin plastic film – and also supplies the two fixed grid electrodes with the music signal, which has been transformed to high voltage. The positively charged membrane is repelled by a positive electrode and at the same time attracted by the negative electrode on the opposite side. If the signal changes its polarity, the membrane is pushed/pulled in the opposite direction – it thus vibrates to the rhythm of the music. The benefit of this converter technology is the almost inertia-free driver, which can react to even the sharpest impulse.

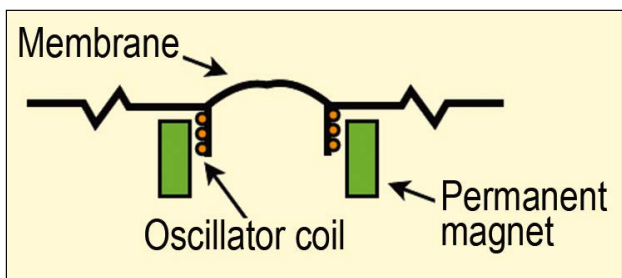

### CLASSIC: DYNAMIC HEADPHONES

Most headphones work on the electrodynamic principle, just like a loudspeaker. An oscillator coil attached to the diaphragm sits in the field of a permanent magnet. The so-called Lorentz force acts on a conductor with a current in the magnetic field, perpendicular to the magnetic field and perpendicular to the direction of the current. So the diaphragm is deflected one way or the other, depending on the direction of the current.

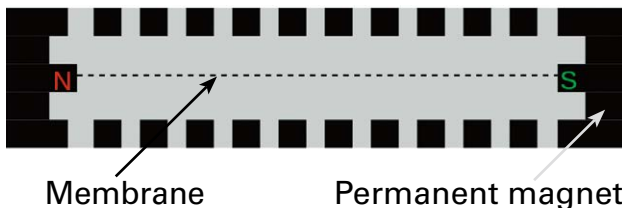

### ALUMINUM STRIPS INSTEAD OF COIL: MAGNETOSTATS

Magnetostats work similarly to dynamic headphones, but in this case aluminum conductor strips are glued onto a thin plastic membrane in a meandering pattern. When current passes through the conductor in a static magnetic field, a force acts on the conductor and deflects the diaphragm. Due to the short conductor length, this force is lower than in a coil, which is why magnetostatic converters are usually less sensitive than dynamic ones.

## CONCLUSION



**MICHAEL LANG**  
Managing editor

Progress sneaks in silently – and yet cannot be missed: this test group featured versions of two proven models with further developments which showed what can still be extracted from a proven system by improving some details.

The mechanics of the Sennheiser HD 800 have been reworked to create the HD 800 S, helping the manufacturer suppress the resonan-

ces, which earned the original design the occasional reputation as a „cold customer“. This coolness has disappeared, and despite reduced high-range reproduction, the transparency has increased, which is especially noticeable when using the balanced cable included. However, the price increase of € 300 for the additional cable doesn't exactly make it a steal.

The Stax has been clearly reworked to a greater extent – with wide-ranging success. The overall sound, and detail resolution have been successfully refined, and while the design is still not exactly the most pleasurable to hold, the illusion of listening to speakers instead of headphones is almost complete, the airiness and transparency in connection with extraordinary comfort standing out among the competition. What's more, the supposed weaknesses like a lack of broad dynamics and

limited weight don't really exist, although the Stax is not suitable for on the road, and only marginally so for a quick drop-in at friends. The amp / supply unit is a must and requires mains power, although admittedly as well as its three inputs, one of which is balanced, there's a pass-through to output signal to an amp and two jacks on the front for listening together. With all this in mind, the price is OK.

The big brother of the Edition X, the HiFiMAN 1000, faced harsh criticism due to its €3000+ tag: for all its sonic ability, we thought the price was simply cheeky for a product made in China. However, the Edition X now does almost the same job for about half the price and can also be used on portable devices, the savings on mechanics and construction unnoticeable in everyday use. This is a truly successful instance of downsizing.